

simalube® – the automatic single-point lubricator



Technical information: elevators and escalators



simalube®
smart lubrication

Elevator lubrication with **simalube**[®]

The guide rails on elevators need to be permanently lubricated in order to prevent dry friction. By dispensing precisely the right amount of lubricant, the **simalube**[®] lubrication system reduces the need for maintenance and cleaning work on the elevator cabin and shaft. It is therefore also a particularly good system to use on maintenance-intensive elevators installed on the outside of buildings and on panoramic elevators.



«**simalube**[®] provides constant lubrication,
extends product life and cuts maintenance
costs»

Diverter Pulley

The **simalube**[®] lubricator is used for lubricating the bearing of the diverter pulley. The lubricator is mounted directly on the grease point of the pulley.

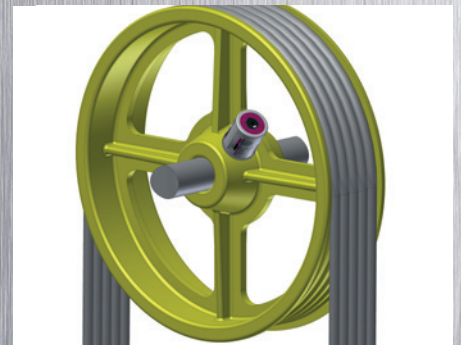

Guide rail

The **simalube**[®] lubrication system is the optimal solution for the guide rail. It protects the rail with a constant film of oil and cleans it at the same time. The **simalube**[®] elevator brush set is fixed directly to the elevator roof or the guide rail shoe.

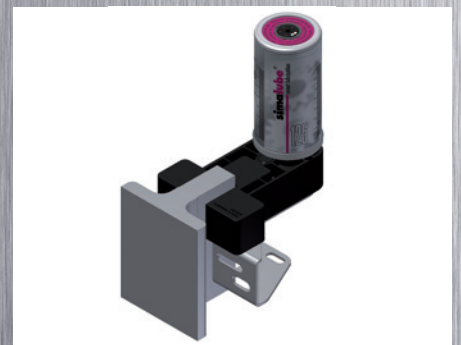

Elevator ropes

The elevator ropes can easily be lubricated with the **simalube**[®] lubricator. Here, the **simalube**[®] square brush continuously applies the lubricant to the ropes and cleans it simultaneously.

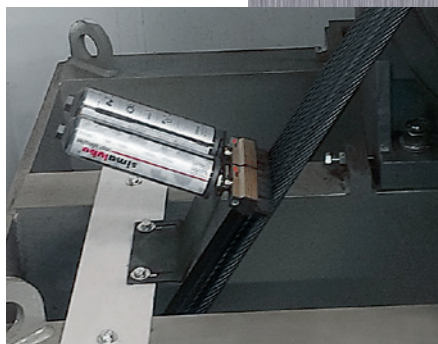

Escalator lubrication with **simalube**[®]

Escalators that are in permanent use often begin to squeak. To avoid this, optimal lubrication of the equipment is required.

simalube[®] lubricates drive chains, step chains and step guides automatically, continuously and economically. The simple installation process, the fully adjustable dispensing period and the pinpoint lubrication accuracy make **simalube**[®] an indispensable system for escalators and moving walkways.



«**simalube**[®] offers lubrication systems for every type of escalator»

Drive chain

The **simalube**[®] dispensing unit oils the chain continuously; the brush set is fixed directly to the U-profile.

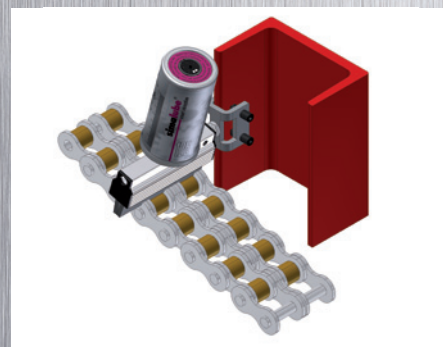

Escalator chain

The brush lubricates the chain links on both sides; the plastic rollers are only slightly dampened.

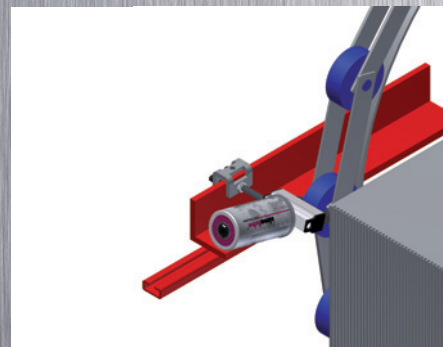
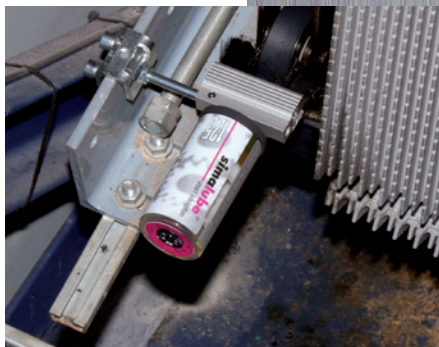

Escalator step guides

The lubrication system comprises a short brush, a mounting kit and a lubricator and is suitable for use with Schindler escalators. The system is fixed directly to the step.

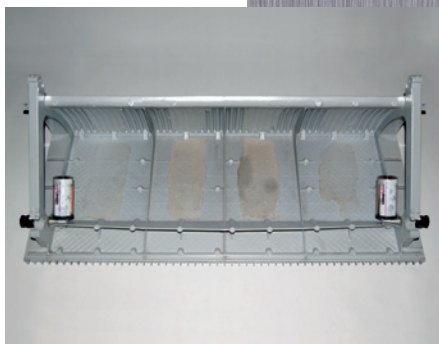

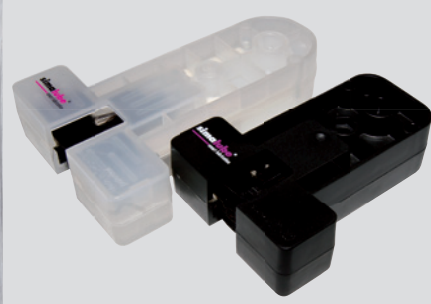
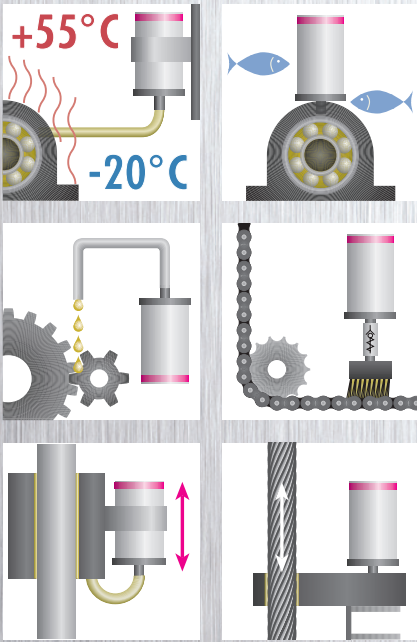

Elevator brush set for the lubrication of guide rails for widths of 5 to 16 mm and depths up to 25 mm.



Applications and advantages

simalube® applications for elevators, escalators and moving walkways:

- **Guide rails**
- **Diverter pulley**
- **Drive chains**
- **Traction cables**
- **Escalator step guides**
- **Step chains**

Benefits of the simalube® lubrication systems:

The easy-to-use **simalube®** lubrication systems guarantee optimal care of elevators and escalators. These special lubrication systems are exceptionally reliable and efficient. Assembly sets are available for retrofitting elevators and escalators made by the best-known manufacturers.

Further benefits:

- Reduction of service requirements and maintenance costs
- No more oil spillage or splashes
- Simple to retrofit existing installations
- Improved occupational safety (no risk of slipping on excess oil)
- Constant application of lubricant
- Stepless setting of lubricant dispensing time from one month to one year
- Refillable oil lubricator

Specific benefits for elevators:

- Reliable lubrication of guide rails and traction cables
- Elevator runs quietly
- Containers to catch excess oil no longer required

Specific benefits for escalators and moving walkways:

- Reliable lubrication of escalator guide rollers, drive chains and step chains
- Silent operation without unpleasant squeaking noises
- Optimally lubricated guides prevent any build-up of electrostatic charge or sparking



If you have any questions about how to use **simalube®** products in elevators and escalators, we will be pleased to advise you further.

Our experts are highly qualified in their field and can show you how to cut costs and extend the life of your equipment with automated lubrication.

simatec ag

Stadthof 2
CH-3380 Wangen a. Aare

Phone: +41 (0)32 636 50 00

Fax: +41 (0)32 636 50 19

welcome@simatec.com

www.simatec.com

simatec
smart technologies